

On the Method of Air Infrared Ecological Control

Ruben Asatryan¹, Hamlet Karayan², Norayr Khachatryan³

^{1,3}National Institute of Metrology, Armenia

²Yerevan State University, Armenia

Abstract:-The results of development of the air infrared radiometer for the realization of monitoring of the environment from an aircraft, and also methods of him some applied applications are presented.

The development results of a new methods of aerial (on a helicopter or airplane) infrared (IR) scanning of extensive spaces with the purpose of detecting weak heat sources (fire centers at an early stage of their development) to prevent the occurrence of large-scale fires are presented, and for probing gas main pipelines and detecting gas leaks also is described. IR scanning of pipelines was performed in the wavelength range 8–12 μm by a helicopter flying along the routes of pipelines.

In the paper there is presented the description of the IR radiometer as well as the measurement method of point and extended thermal sources in the wavelength range of 2.5 to 5.5 and 8-12 microns.

Keywords:- Infrared Radiometer, Forest Fire, Natural Gas Pipelines.

I. INTRODUCTION

The environment monitoring, investigation and control of ecological conditions attract a great attention of the mankind, especially at the present stage of development of industry, energetic and urban building. Optoelectronic systems and devices designed for application in ecological studies and in arising extremal situations are always in the center of the scientists' and engineers' attention. In particular, research complexes for early detection of fire hearths arising during natural calamities are irreplaceable.

The main artificial source of atmospheric gaseous pollution is leakage of natural gas, in which the methane content is 95%. However, the problem is aggravated by the fact that gas main pipelines (GMPs) run through sparsely inhabited and hard to reach territories, where testing is especially impeded.

It is obvious that the development of a state of the art remote and efficient method for ecological monitoring of GMPs is especially pressing. In this situation, the only practical method is remote testing from an aircraft (e.g., a helicopter) flying along the pipeline route at heights of up to 1000 m.

The objective of this study is the description of a universal spectroradiometer (SR) we developed and demonstration that one possible field of its application is the airborne IR monitoring of GMPs.

Therefore, the development and creation of infrared devices and systems of thermal monitoring of environment, in particular, large forest spaces is a rather important problem.

The development of modern distant and effective methods of ecological monitoring of large forest spaces is more than actual. In such a situation the only method is remote monitoring from an aircraft (e.g., from a helicopter) while flying over large forests at the altitude up to 1000 m.

II. BRIEF TECHNICAL DESCRIPTION OF A MEASURING SYSTEM

Structurally the measuring complex consists of two basic units: an optico-mechanical unit of the IR radiometer and an electronic control unit joined to a personal computer. It is designed to measure spectral radiance and radiation temperature (or its drops) of point and extended sources of infrared radiation under laboratory and field conditions [1-4]. To automate data acquisition and processing the spectroradiometer is joined to a personal computer via a series port RS 232. Optical scheme of the optico-mechanical unit (OMU) is shown in Fig.1.

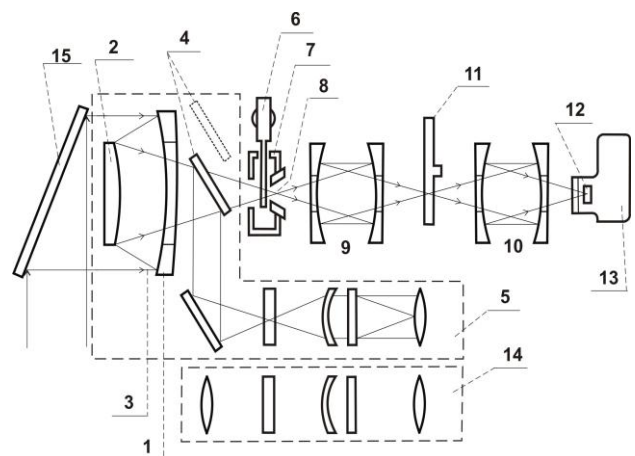

Fig. 1. Optical scheme of OMU.

1-Primary mirror of the objective; 2- secondary mirror of the objective; 3- radiation from an object; 4- removable plane mirror; 5- a sight; 6- a modulator; 7- a reference cavity; 8- a field diaphragm; 9,10- projection objective; 11- a disk with interferential light filters; 12- a sensing site of the photodetector, 13-corps of photodetector, 14- a telescope; 15- a deflection mirror.

- Input mirror objective of Cassegrain type;
- A telescope for operative pointing to an object under test, equipped with a sighting grid visible through an eyepiece on the OMU back panel;
- Parallax free sight for accurate pointing the spectroradiometer to an area to be measured. The sight has a sighting grid with a cross and a circle which defines visual field boundaries of the device;

- Projection objectives which serve for refocusing the radiation from a field diaphragm to the plane with light filters and to a sensing site of the photodetector. They represent pairs of spherical mirrors the application of which enables to avoid achromatic aberrations;
- A disk with interferential light filters which provide a total working spectral range of 2,5 to 14 μ m;
- A photodetector IRA – E410ST1 a preamplifier, and an adjusting

Full working spectral range of the device is covered with the help of two sets of interferential light filters and photodetector in the subbands of 2.5 to 5.5 μ m, and 8 to 14 μ m. Main technical parameters of the device are given in the Table.

№	Parameter Name	Value
1.	Input objective diameter	180 mm
2.	Focal distance mechanism.	200 mm
3.	Distances to be focused	from 5m to ∞
4.	Working spectral range II subband (spectral resolution of 3 %) III subband (spectral resolution of 8 %)	from 2,5 to 14 μ m from 2,5 to 5,5 μ m from 7,9 to 13,5 μ m
5.	Photodetector: II subband III subband	IRA – E410ST1
6.	Field of vision	3 mrad
7.	Noise equivalent difference of the radiation temperatures (at 295° K)	0,05 K
8.	Time of preparation to work	15 min
9.	Dimensional size of spectroradiometer: OMU ECU	415x278x254 mm 500x420x210 mm
10.	Weight: OMU ECU	not more than 12 kg not more than 15 kg
11.	Climatic conditions of operation: Ambient temperature Atmospheric pressure Air relative humidity	from –35° to +45° from 84 to 107 kPa (from 630 to 800 mm Hg) up to 98% at 35°C
12.	Supply voltage frequency	(220 \pm 22) V (50 \pm 1)Hz
13.	Power consumed	not more than 200W

During operation the OMU, by means of the wedge guide, is placed on a rotary mechanism which is fastened to the horizontal platform of a specially prepared tripod

The electronic control unit (ECU) is structurally of on-top variant. All indication and control elements are mounted on the front panel of the ECU.

Appearance Under laboratory conditions the ECU is placed on the table, and under field conditions it can be

mounted in a helicopter with the help of dampers. External of the units is shown in Fig.2.

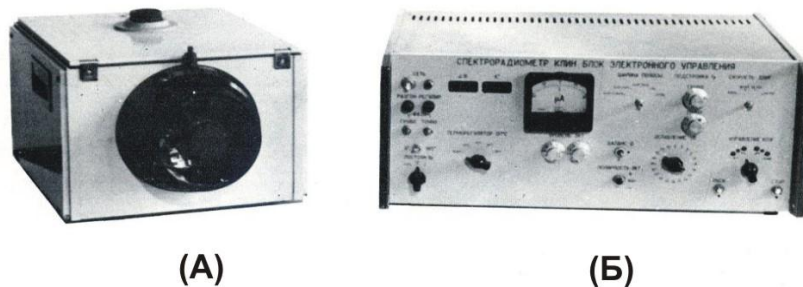

Fig. 2. External appearance of the radiometer A)OMU, B) ECU

In brief, the operation principle of the spectroradiometer consists in the following: Inside the OMU the radiation flow from the object under test is collected by means of an optical system (see Fig.1) and focused onto a sensing site of the photodetector. Further, a preamplifier amplifies an electric signal and transmits it to the ECU. In the ECU the electronic schemes amplify, demodulate and filter the signal from the photodetector output, and as a result of this there appears a signal at the output the amplitude of which is a measure of the radiation temperature of the object. Knowing the value of the collected radiation power (through the data of preliminary conducted energetic calibration of the device), spectral filter features of the system and amplification degree, the output signal can be exactly transformed into an absolute measurement of radiation temperatures of the objects under test.

Let's notice some advantages of the IR radiometer developed by us [5] compared to the existing close analogs. To widen functional capabilities in the sphere of spectral investigations of thermal objects, besides wideband interferential light filters for spectrum parts of 0.4 to 1.1, 2.5 to 5.5., and 8 to 14 μm , the device is also provided with ring readjustable light filters. To eliminate chromatic aberrations the device optical scheme includes two pairs (see Fig.1) of mirror projection objectives in the focuses of which there are placed light filters and the receiving site of photodetectors.

The IR radiometer is mounted in the helicopter and, with the help of a deflecting plane mirror, by its field of vision scans (through the bottom hatch, along the helicopter motion routing) terrestrial surface of large forests, see Fig.3.



Fig. 3. Helicopter IR scanning of large forests.

In the presence of fire hearths the radiation temperature in this region (within the wavelength range

of 2.5 to 5.5 μm) considerably increases that is registered by the electronic control unit.



Fig. 4. Helicopter IR scanning of GMPs.

At the helicopter flight altitudes of 200, 500 and 700 m the radiometer covers, with its field of vision, surface areas of about 120, 750 and 1500 sq.m, correspondingly.

The IR radiometer scans the Earth's surface along the GMPs routes within its field of view through the bottom hatch. If there are macroscopic gas leaks in this region, the radiation temperature (in the wavelength region 8–14 μm) drops significantly [6] and is recorded by the ECU.

At helicopter flight altitudes of 200 and 150 m, the radiometer fields of view on the ground encompass surfaces with radius of ~6 and ~2.5 m, respectively, see fig. 4.

With the helicopter speed of 150-200 km/hr the time of one measurement cycle is 0.1 sec.

III. MEASUREMENT TECHNIQUE OF IR FLOWS FROM EXTENDED AND POINT THERMAL SOURCES

Before carrying out quantitative measurements of IR radiation emitted by an unknown source, it is necessary to fulfill energetic calibration of the spectroradiometer, the aim of which is the measurement of the device response to the known standard source (usually a black body with known temperature). By definition, the device calibration means obtaining an electrical signal at the output, which corresponds to a radiation flow unit incident into the radiometer inlet.

The calibration is expressed by some function $k(\lambda)$ called spectral calibration characteristic of the device, which includes combined effect of optical elements and electronic amplification of the whole system. $k(\lambda)$ is expressed in V/radiation unit, with standard level of amplification degree. An output signal of the device is proportional to the difference between the IR radiation flows coming to the photodetector from an external source and from the internal modulated reference black body. In calibrating the radiation from the calibration black body (with known temperature) entirely fills the device field of vision. An output signal $S(\lambda)$ is expressed by the following ratio:

$$S(\lambda) = k(\lambda) \cdot \{r(\lambda, T) \cdot \tau(\lambda, l) - r(\lambda, T_0) + r(\lambda, T_B)\} [1 - \tau(\lambda, l)] \quad (1)$$

Where $r(\lambda, T)$ is Plunk function at the temperature T and the wavelength λ ;

T – temperature of the calibration black body;

$\tau(\lambda, l)$ – atmospheric transparency over the path l between the calibration source and device;

T_0 – temperature of the internal reference black body;

T_B – temperature of the air during the experiment.

In the windows of the atmosphere transparency (e.g. for the wavelength range of 2.5 to 5.5 μm), where the transmission is high, $\tau(\lambda, l)$ may be taken as 1, if the calibration is carried out from the distance “ l ” equal to several meters. Therefore in this approximation for $S(\lambda)$ we can write:

$$S(\lambda) = k(\lambda) \cdot [r(\lambda, T) - r(\lambda, T_0)] \quad (2)$$

With the amplification coefficient equal to 1. And in measuring with the amplification coefficient different from 1 the $S(\lambda)$ value decreases by the same factor.

The Plunk function value is calculated according to the ratio:

$$S(\lambda) = k(\lambda) \{ W(\lambda, T) \cdot \tau(\lambda, l) - r(\lambda, T_0) + r(\lambda, T_B) [1 - \tau(\lambda, l)] \} \cdot \beta \quad (3)$$

Where $W(\lambda, T)$ is the radiance spectral density of the object studied, β is an amplification coefficient of the whole system, and the rest symbols remain previous.

$$W(\lambda, T) = \frac{S(\lambda) / k(\lambda) \beta + r(\lambda, T_0) - r(\lambda, T_B) \cdot [1 - \tau(\lambda, l)]}{r(\lambda, l)} \quad (4)$$

Usually the radiation of point sources does not fill the visual field of the device. If the area A of a radiating object is known we can measure its spectral radiance according to the above-stated technique, that is

$$W_p(\lambda, T) = W(\lambda, T) \cdot \omega \cdot \frac{l^2}{A} \quad (5)$$

Where ω is a solid angle of the spectroradiometer visual field, $W(\lambda, T)$ is a total spectral radiance measured according to (4); l is the distance from the object under test to the spectroradiometer. While measuring point sources spectral contrast of a radiation source is also of interest, when the background radiance is comparable to the object radiation. In this case it is necessary to separate the background signal $S_\phi(\lambda)$ from the signal “source+background” $S(\lambda)$. For the spectral radiation contrast of the source we can get the ratio:

$$W(\lambda) = \frac{\Delta S(\lambda) \cdot \omega \cdot l^2}{\beta \cdot k(\lambda) \cdot \tau(\lambda, l) A} \quad (6)$$

Where $\Delta S(\lambda) = S(\lambda) - S_\phi(\lambda)$

If A is unknown we may define the contrast of the spectral luminous intensity of the source (in $W/\text{strad} \cdot \mu\text{m}$):

$$r(\lambda, T) = \frac{c_1}{\lambda^5} [\exp(c_2 / \lambda T) - 1]^{-1}$$

Where

$$c_1 = 3,74 - 10^4 \text{ W } \mu\text{m}^4/\text{cm}^2$$

$$c_2 = 1,438 \cdot 10^4 \text{ } \mu\text{m deg}$$

The objects studied the radiation flow of which completely fills the device field of vision are extent in these measurements. In this case radiance spectral density ($W(\lambda, T) W/\text{cm}^2 \mu\text{m}$) of the object is measured. The ratio (1) may be rewrite as:

The atmosphere transparency $\tau(\lambda, l)$ is either measured simultaneously, or calculated with the help of data from literature [7,8]. From the ratio (3) we can get for $W(\lambda, T)$:

$$I(\lambda) = W(\lambda) \cdot A = \frac{\Delta S(\lambda)}{\beta \cdot k(\lambda) \cdot \tau(\lambda, l)} \cdot \omega \cdot l^2 \quad (7)$$

Calculation of the radiation temperatures of the objects under test is carried out in accordance with specially developed algorithms and programs.

IV. CONCLUSION

Application of the given method of remote ecological monitoring of vast forest spaces and extended gas pipelines will undoubtedly bring to the considerable technical-economical effectiveness and will also have a great importance in the problem of preventing the fire occurrences, especially of large-scale ones, and also will be imported in solving the problem of monitoring atmospheric pollution from natural – gas emissions.

REFERENCES

- [1] R.S.Asatryan, N.R.Khachatryan, H.S.Karayan, (2015), “On the Method of Distant Infrared Monitoring of Forest Spaces and Ctas Main Pipelines, American Research Journal of Agriculture, Vol.1 Issue 2, April :Page, 1-6
- [2] R.S Asatryan, (2007), Optoelectronic Methods and Means of Intesting Physico-Ecological Parameters of Atmosphere and Thermal Objects, News of NAS RA, Techn. Sciences, Vol. LX, No. 2,Page, 307(in Russian).
- [3] R.S Asatryan , S.R Asatryan , et al.,(2008), Infrared Scanning Complex for Preventing Large-Scale Fires, Ecological Systems and Devices, No. 1, Page 17 (in Russian).



International Journal of Recent Development in Engineering and Technology

Website: www.ijrdet.com (ISSN 2347-6435(Online) Volume 6, Issue 4, April 2017)

- [4] R.S. Asatryan et al.(2003), Universal Infrared Spectral Radiometer. Intern. Journal of IR and MM Waves, vol . 24, No. 6,Page, 1035.
- [5] R.S. Asatryan, H. G. Gevorgyan et al.(2005), The Spectroradiometer, Patent of Ra, No.1678A2, Appl. No. P20050042, 11.04.2005. (in Armenian).
- [6] Shilin, B.V. and Molodchinin, I.A.,(1992) Kontrol' sostoyaniya okruzhayushchei sredy teplovoi aeros'emkoi (Monitoring of Environment by IR Aerial Survey), Moscow: Nedra, Pages 186, (in Russian).
- [7] P. Kruz , L.Macgloulin ,P. Maccvistan , (1964) Bases of Infrared Technique, M. Voenizdat, USSR DD, 464pages, (in Russian).
- [8] A.V. Pavlov, (1974), Optoelectronic Devices, M. Energia, 360pages (in Russian).