

Circularly Polarized Square Patch Antenna.

Manoj Sengar¹, Hamid Ali², Gaurav Kumar³

Shobhit University Meerut

Abstract— This paper presents the result for different standard thickness values, and the result is performed by circularly polarized, Square patch antenna with a small frequency-ratio is proposed for mobile applications. The antenna has become a necessity for many applications in recent wireless communications such as Radar, Microwave and space communication. The proposed antenna design on different shapes and analyzed result in resonant frequency will be 8.2GHz. A single micro-strip feed-line is underneath the centre of the coupling aperture ground-plane. The frequency-ratio of the antenna can be controlled by adjusting the slot arm lengths. At 12GHz frequency and the tested result on IE3D SIMULATOR parameters are for X-axis -21.6mm to 21.6mm, Y-axis -21.6mm to 21.6 . After that results are verified and simulated, S-Parameter = -25.34dB, Field Gain = 9.463dB, Directivity = 10.57dB, Efficiency for Antenna = 77.75% and VSWR = 0.97 . All results shown are Simulated.

Keywords— Micro strip antenna; IE3D SIMULATOR; Circular polarization; circularly polarized antenna; slotted patch; slot.

I. INTRODUCTION

Micro strip patch antenna used to send onboard parameters of article to the ground while under operating conditions. The aim of the thesis is to design and fabricate an inset-fed circular polarization Micro strip Patch Antenna and study the effect of antenna dimensions Length (L) , Width (W) and substrate parameters relative Dielectric constant (ϵ_r), substrate thickness (t) on the Radiation parameters of Bandwidth and Beam-width New wideband stacked micro-strip antennas for enhancing bandwidth. Major issue for micro strip antenna is narrow bandwidth.

A) Overview of Micro strip Antenna

A micro strip antenna consists of conducting patch on a ground plane separated by dielectric substrate. This concept was undeveloped until the revolution in electronic circuit miniaturization and large-scale integration in 1970. After that many authors have described the radiation from the ground plane by a dielectric substrate for different configurations. The early work of Munson on micro strip antennas for use as a low profile flush mounted antennas on rockets and missiles showed that this was a practical concept for use in many antenna system problems.

Various mathematical models were developed for this antenna and its applications were extended to many other

fields. The number of papers, articles published in the journals for the last ten years, on these antennas shows the importance gained by them. The micro strip antennas are the present day antenna designer's choice.

Low dielectric constant substrates are generally preferred for maximum radiation. The conducting patch can take any shape but rectangular and circular configurations are the most commonly used configuration. Other configurations are complex to analyse and require heavy numerical computations. A micro strip antenna is characterized by its Length, Width, Input impedance, and Gain and radiation patterns. Various parameters of the micro strip antenna and its design considerations were discussed in the subsequent chapters. The length of the antenna is nearly half wavelength in the dielectric; it is a very critical parameter, which governs the resonant frequency of the antenna. There are no hard and fast rules to find the width of the patch.

B) Waves on Micro strip

The mechanisms of transmission and radiation in a micro strip can be understood by considering a point current source (Hertz dipole) located on top of the grounded dielectric substrate (fig. 1.1) This source radiates electromagnetic waves. Depending on the direction toward which waves are transmitted, they fall within three distinct categories, each of which exhibits different behaviours

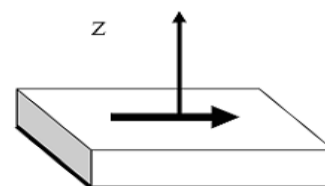

Figure 1.1 Hertz dipole on a microstrip substrate

Micro strip patch antenna consists of a radiating patch on one side of a dielectric substrate which has a ground plane on the other side. The radiating patch may be any shape as shown in Fig. 1.1(a)

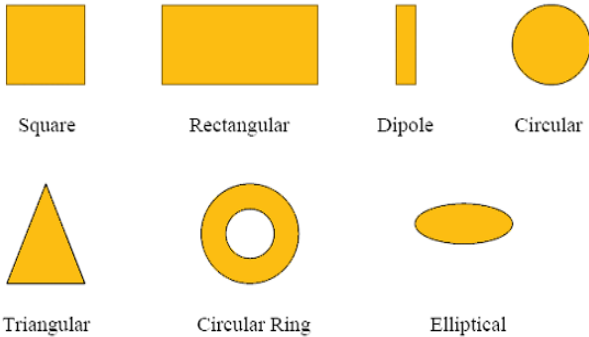

Fig. 1.1(a) Common shapes of micro strip patch elements

C) Surface Waves

The waves transmitted slightly downward, having elevation angles θ between $\pi/2$ and $\pi - \arcsin(1/\sqrt{\epsilon_r})$, meet the ground plane, which reflects them, and then meet the dielectric-to-air boundary, which also reflects them (total reflection condition). The magnitude of the field amplitudes builds up for some particular incidence angles that leads to the excitation of a discrete set of surface wave modes; which are similar to the modes in metallic waveguide.

The fields remain mostly trapped within the dielectric, decaying exponentially above the interface (fig1.2). The vector α , pointing upward, indicates the direction of largest attenuation. The wave propagates horizontally along β , with little absorption in good quality dielectric. With two directions of α and β orthogonal to each other, the wave is a non-uniform plane wave. Surface waves spread out in cylindrical fashion around the excitation point, with field amplitudes decreasing with distance (r), say $1/r$, more slowly than space waves. The same guiding mechanism provides propagation within optical fibres.

Surface waves take up some part of the signal's energy, which does not reach the intended user. The signal's amplitude is thus reduced, contributing to an apparent attenuation or a decrease in antenna efficiency. Additionally, surface waves also introduce spurious coupling between different circuit or antenna elements. This effect severely degrades the performance of micro strip filters because the parasitic interaction reduces the isolation in the stop bands.

In large periodic phased arrays, the effect of surface wave coupling becomes particularly obnoxious, and the array can neither transmit nor receive when it is pointed at some particular directions (blind spots). This is due to a resonance phenomenon, when the surface waves excite in synchronism the Floquet modes of the periodic structure. Surface waves reaching the outer boundaries of an open micro strip structure are reflected and diffracted by the edges.

The diffracted waves provide an additional contribution to radiation, degrading the antenna pattern by raising the side lobe and the cross polarization levels. Surface wave effects are mostly negative, for circuits and for antennas, so their excitation should be suppressed if possible.

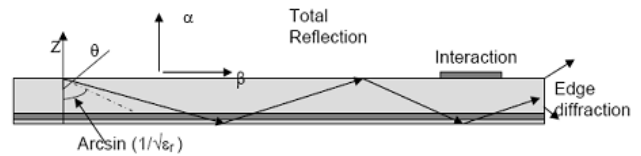

Figure 1.2. Surface waves

D) Guided Waves

When realizing printed circuits, one locally adds a metal layer on top of the substrate, which modifies the geometry, introducing an additional reflecting boundary. Waves directed into the dielectric located under the upper conductor bounce back and forth on the metal boundaries, which form a parallel plate waveguide. The waves in the metallic guide can only exist for some Particular Values of the angle of incidence, forming a discrete set of waveguide modes. The guided waves provide the normal operation of all transmission lines and circuits, in which the electromagnetic fields are mostly concentrated in the volume below the upper conductor. On the other hand, this build up of electromagnetic energy is not favourable for patch antennas, which behave like resonators with a limited frequency bandwidth.

E) Antenna Characteristics

An antenna is a device that is made to efficiently radiate and receive radiated electromagnetic waves. There are several important antenna characteristics that should be considered when choosing an antenna for your application as follows:

- Antenna radiation patterns
- Power Gain
- Directivity
- Polarization

II. MATHEMATICAL ANALYSIS

Theoretical analysis and calculations from of all dimensions will be obtained;

The width of the patch element (W) is given by.

$$W = \frac{c}{2f_0 \sqrt{\frac{\epsilon_r + 1}{2}}}$$

Substituting $c = 3 \times 10^8$ m/s, $\epsilon_r = 2.2$, and $f_0 = 5$ GHz, then $W = 2.3717$ cm or 933.74 mile.

The effective of the dielectric constant (ϵ_{reff}) depending on the same geometry (W, h) but is surrounded by a homogeneous dielectric of effective permittivity ϵ_{reff} , whose value is determined by evaluating the capacitance of the fringing field.

$$\epsilon_{\text{reff}} = \frac{\epsilon_r + 1}{2} + \frac{\epsilon_r - 1}{2} \left[1 + 12 \frac{h}{W} \right]^{-\frac{1}{2}}$$

Substituting $\epsilon_r = 2.2$, $W = 2.3717\text{cm}$, and $h = 0.1575\text{cm}$, then

$\epsilon_{\text{reff}} = 2.1074\text{cm}$ or 829.69mile , The effective length (L_{eff}) is given:

$$L_{\text{eff}} = \frac{c}{2f_o \sqrt{\epsilon_{\text{reff}}}}$$

Substituting $c = 3 \times 10^8 \text{ m/s}$, $\epsilon_{\text{reff}} = 2.0475\text{cm}$, and $f_o = 5 \text{ GHz}$, then $L_{\text{eff}} = 2.0665\text{cm}$ or 813.6 mile .

The length extension (ΔL) is given by:

$$\Delta L = 0.412h \frac{(\epsilon_{\text{reff}} + 0.3) \left(\frac{W}{h} + 0.264 \right)}{(\epsilon_{\text{reff}} - 0.258) \left(\frac{W}{h} + 0.8 \right)}$$

Substituting $\epsilon_{\text{reff}} = 2.1074\text{cm}$, $W = 2.3717\text{cm}$, and $h = 0.0787\text{cm}$, then $\Delta L = 0.041469\text{cm}$ or 16.3266mile .

The actual length (L) of patch is obtained by:

$$L = L_{\text{eff}} - 2\Delta L$$

Substituting $\Delta L = 0.041469\text{cm}$, and $L_{\text{eff}} = 2.0665\text{cm}$, then $L = 1.9835\text{cm}$ or 780.92mile .

III. ANTENNA DESCRIPTION

The results of proposed circular polarised Multiband micro strip patch antenna verified in IE3D Simulator with optimization.

A. Proposed Equivalent circuit:

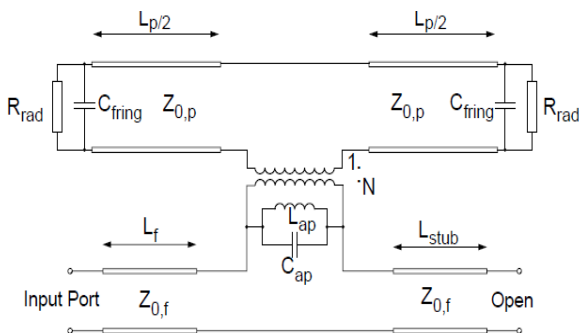
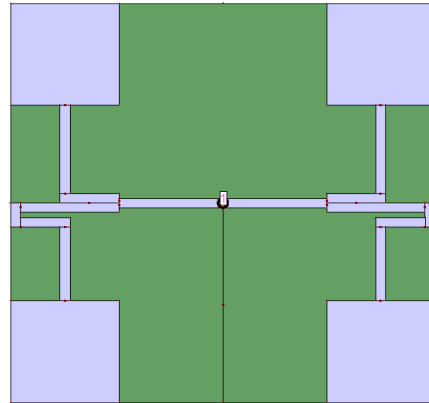

Fig. Equivalent circuit for an aperture-coupled micro-strip antenna

IV. PROPOSED ANTENNA



V. RESULTS AND DISCUSSION

Simulated Results:-

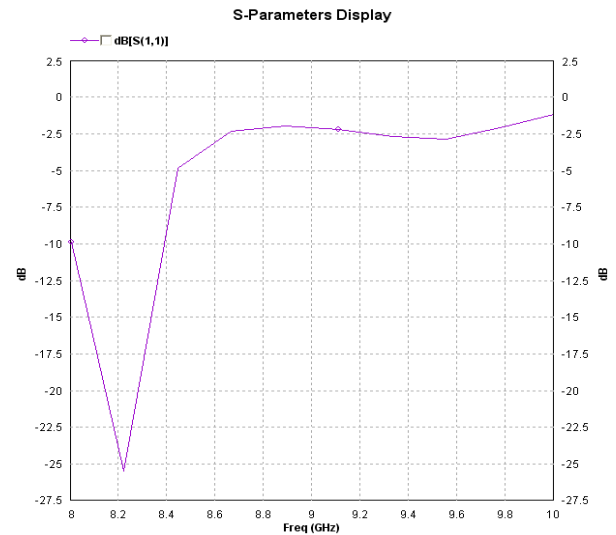

S-parameter

Axial-Ratio Vs. Frequency

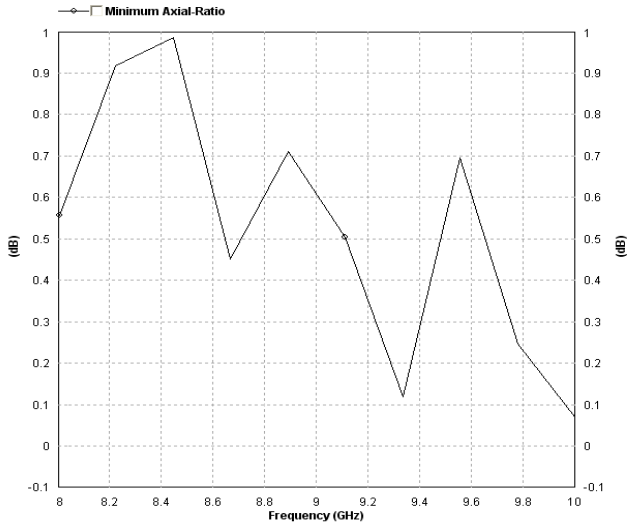

Axial Ratio

3D radiation pattern display

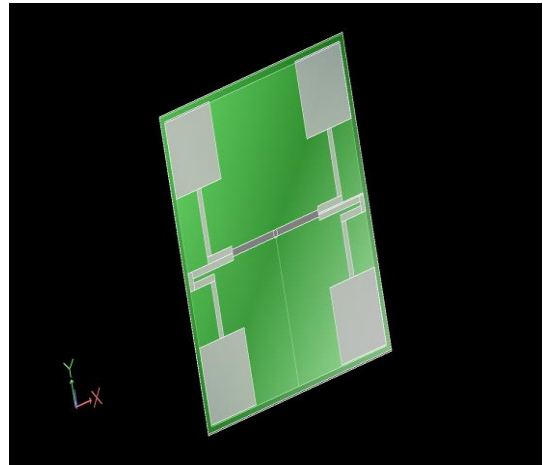

Total Field Directivity vs. Frequency

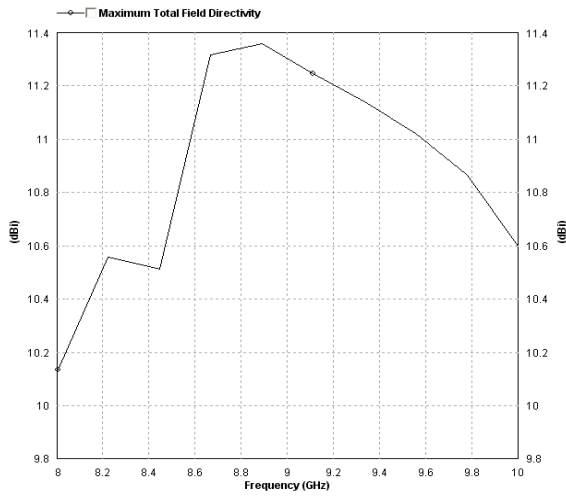

Efficiency Vs. Frequency

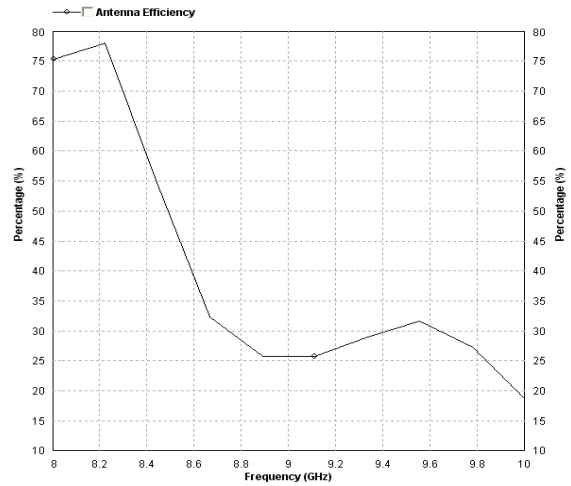

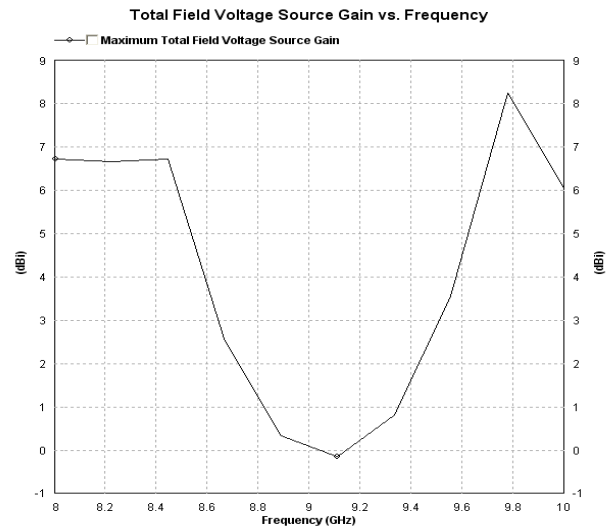
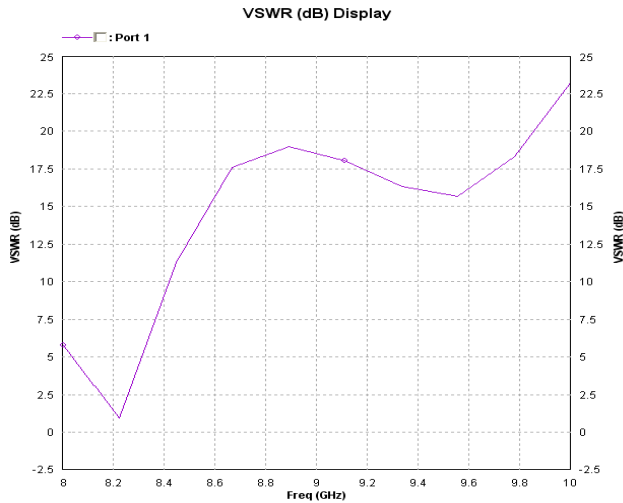

Tabular Description Of Results :

Resonant Frequency in GHz	Return loss (in dB)	Axial Ratio (in dB)	Field Gain (in dB)	Field Directivity (in dB)	Efficiency (in %)
8.22	-25.34	0.9854	9.463	10.57	77.75

VI. CONCLUSION

Micro strip antennas have become a rapidly growing area of research. Their potential applications are limitless, because of their light weight, compact size, and ease of manufacturing. One limitation is their inherently narrow bandwidth. However, recent studies and experiments have found ways of overcoming this obstacle. A variety of approaches have been taken, including modification of the patch shape, experimentation with substrate parameters, Most notably mobile communication systems where many frequency ranges could be accommodated by a single antenna. We here design simple and low costlier patch antenna for pervasive wireless communication by using different patch length. The transmission line model seems to be the most instructive in demonstrating the bandwidth effects of the changing the various parameters. The proposed frequency range 10 GHz (Ku Band) and Analysis Radiation Characteristics of micro strip antenna by IE3D Simulator. The results of proposed designing are effective between 8GHz-10GHz. proposed antenna simulated in IE3D Simulator. The optimum results of proposed antenna verify and tested in IE3D SIMULATOR. The simulated results of IE3D at Directivity = 10.577 dB, Efficiency for Antenna= 77.7%, Return loss = -25.34 dB and Field Gain = 9.46dB.

The proposed single-feed square-patch circular polarized antenna is useful for small frequency-ratio in wireless Communication.

REFERENCES

- [1] C.A. Balanis, "Antenna theory", John Wiley, 1982, pp 727-734.
- [2] David M. Pozar. Considerations for millimeter wave printed antennas. IEEE Transactions on Antennas and Propagation, 31(5):740-747, 1983.
- [3] David M.Pozar. Microstrip antenna aperture{coupled to a microstrip-line. Electronic Letters, EL{21(2):49{50, January 1985.
- [4] S. D. Targonski and D. M.Pozar, "Design of wideband circularly polarized aperture-coupled microstrip antennas," IEEE Trans. Antennas Propag., vol. 41, no. 2, pp. 214–219, 1993.
- [5] T. Tanaka, T. Houzen, M. Takahashi, and K. Ito, "Circularly polarized printed antenna combining slots and patch," IEICE Trans. Commun., vol. E90-B, no. 3, pp. 62–628, 2007.
- [6] C. H. Cai, J. S. Row, and K. L. Wong, "Dual-frequency micro strip antenna for dual circular polarization," Electron. Lett., vol. 42, no. 22, pp. 1261–1262, Oct. 2006.
- [7] [Georg Splitt. MultiSTRIP v2.4 - User's Manual for the MultiSTRIP Program. Fachhochschule Kiel, 1995
- [8] C.-M. Su and K.-L.Wong, "A dual-band GPS microstrip antenna," Microw. Opt. Technol. Lett., vol. 33, no. 4, May 2002.
- [9] D. M. Pozar and S. M. Duffy, "A dual-band circularly polarized aperture-coupled stacked microstrip antenna for global positing satellite," IEEE Trans. Antennas Propag., vol. 45, no. 11, pp. 1618–1624, 1997.
- [10] IE3D Version 14.0, Zeland Software Inc.. Fremont, CA, Oct. 2007.
- [11] Xian Hua Yang and Lotfollah Shafai. Characteristics of aperture coupled microstrip antennas with various radiating patches and coupling apertures. IEEE Transactions on Antennas and Propagation, AP{43(1):72-78, January 1995.
- [12] Jean-Fran_cois Z_lurcher. The SSFIP: A global concept for high-performance broadband planar antennas. Electronic Letters, EL-24(23):1433-1435, November 1988.