



International Journal of Recent Development in Engineering and Technology
Website: www.ijrdet.com (ISSN 2347-6435(Online) Volume 10, Issue 3, March 2021)

A New Air-Conditioning System of Liquid Desiccant Cooling: A Review

Mohnish Pavaskar¹, Vipul Baria², Yash Patel³, Meet Machhi⁴, Yatish Modi⁵

^{1,2,3,4,5}Laxmi Institute of Technology, Sarigam, Valsad, Gujarat, India

¹170860119043@laxmi.edu.in, ²170860119005@laxmi.edu.in, ³170860119042@laxmi.edu.in,

⁴170860119023@laxmi.edu.in, ⁵170860119045@laxmi.edu.in

Guided by: Assistant Professor Mr. Hemant Patel, Laxmi Institute of Technology, Sarigam

Email ID: hemant.lit@laxmi.edu.in

Abstract-- Use of Air Conditioning System is increased on large scale seems last few years. Along with human comfort different kind of pollution factors too have been arise due to use of this kind of system. To reduce polluting the atmosphere and ozone layer depletion from harmful gases a system has been designed named Desiccant Liquid Air Conditioning System. With the use of Desiccant Liquid Air Conditioning system we can get the cool air without harming the environment. Liquid Desiccant helps to dehumidify the air which is further cooled and cool air is obtained. This Desiccant Liquid Air Conditioning system is designed for domestic use only. It can be used in small areas like office, cabinets etc.

This paper presents the theoretical/imaginary operating view of Desiccant Liquid Air Conditioning system as well as merits and demerits of the system. Further it describe its utilization and processes carried by the system.

Keywords-- Liquid desiccant air conditioning system, evaporation cooling, dehumidifier, regenerator

I. INTRODUCTION

Nowadays, air conditioning systems are commonly and frequently used is domestic as well as industries and in vehicles too due to rise in temperature . Which has increased the pollutions and ozone layer depletion. Therefore many alternative systems are being developed worldwide. Similarly we have developed a system which is eco-friendly, economic and efficient. This is desiccant liquid air conditioner. Now a day's AC (Air Conditioner) system is really very expensive to produce good insulation.

COP(coefficient of performance),it is the amount of heat energy measured in watt pumped per watt of energy spend in the process and higher the COP more efficient unit is going to produce.

So, what our group was going to make is far more efficient than a typical compressor based phase change AC system and working fluid in this case is water.

Water is a makeable fluid in that it can soon uses a tremendous amount of energy to change the phase of water from liquid to vapor or vapor to liquid. It takes 5 times as much energy to take 100 degree Celsius water and converted into 100 degree Celsius vapor as it takes to take the same quantity of water and bring it to all the way up from 0 degree Celsius freezing cold to all the way up 100 degree Celsius in the first place and conversely the same amount of energy is released when that water vapor condenses to a liquid. So, to take advantage of that what we are going to demonstrate here is the power of that phase change in water.

II. SOLID DESICCANTS

Solid desiccants are also called adsorbents . They are the desiccants which do not changes its any physical or chemical properties during regeneration process. Example of solid desiccant is silica gel, activated charcoal, activated alumina,zeolite etc.Solid desiccants have more surface area per unit mass.They absorbs water molecules due to existence of a electric field at the surface. The electric field is not uniformly charged.So they can attract polarized water molecules due to the instability in terms of charges. The solid desiccant absorbs the water molecule due to the difference in vapour pressure in between the molecule and the environmental air.

III. LIQUID DESICCANTS

Liquid desiccants are also called absorbents. They are the desiccants which changes either chemically or physically during the regeneration process. They are generally some strong ionic solution like lithium chloride and calcium chloride. The absorption capacity of liquid desiccants can be changed by changing its concentration and temperature. Temperature is controlled by using heater and cooler. Concentration is changed by changing the moisture contents in it. This is done by heating or spraying. An overview of classification of desiccants and their different regenerating methods are discussed in table-I.

Classification of desiccant	Example	Indication of saturation	Regeneration technique used
Solid	Silica gel, Activated charcoal Do not changes physically or chemically Solar Energy[1,2,5,6,7, 8,14,15,16,17,] Activated alumina, Zeolite etc	Do not changes physically or chemically	Solar Energy[1,2,5,6,7, 8,14,15,16,17,1] Activated alumina, Zeolite etc Latent heat storage[4], Ultrasonic wave[19] Electric heating[21], Electro osmosis[9,11,13] Microwave[10,12,20], Electrochemical process
Liquid	Lithium Chloride, Calcium Chloride Changes either chemical or physical property Solar Energy[22,23,26, 27,28,29,30,31, 32,33,34,36] NaX, NaY etc	Changes either chemical or physical property	Solar Energy[22,23,26, 27,28,29,30,31,32,33,34,36] NaX, NaY etc Spray chamber and process air [24,25,35]

In past few decades the use of desiccant material in the dehumidification of air or other gases have increased to a large extent and consequently the researcher have also studied different technology for regeneration of both solid and liquid desiccants. Here, some methods are discussed for both solid and liquid desiccants separately:

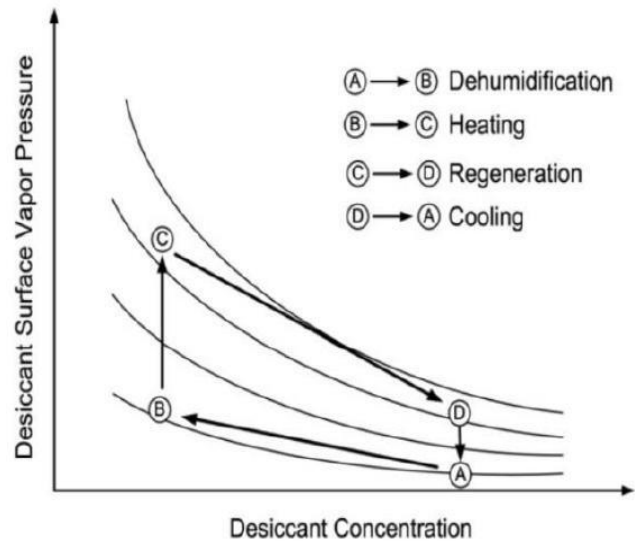

IV. LIQUID DESICCANT SYSTEMS

A simple LDS containing dehumidifier and regenerator is shown in Fig. 2. Moisture from the air is absorbed by the desiccant because of difference in vapour pressure between air and the surface of desiccant solution. Dehumidification takes place until vapour pressure of desiccant reaches equilibrium with air. After dehumidification, air is sent to evaporative cooler to cool down to the required temperature whereas the diluted desiccant solution is sent to the regenerator. Before sending the desiccant directly to the regenerator, it is initially passed through a sensible heat exchanger where its temperature is raised. After that, the liquid is exposed to regenerative air and due to difference in vapour pressure; the moisture is transferred from solution to air. Now this concentrated solution is again passed through heat exchanger and a cooling coil before it is sent to dehumidification unit. Here, heat exchangers are used to pre-heat the weak solution and pre-cool the strong solution.

V. METHODOLOGY

Desiccant liquid is generally used for the dehumidification of air. It removes moisture as well as dry particles from it. We have used LiCl desiccant liquid in our system which will provide more efficient dehumidified air. As desiccant liquid do not harm environment as well as it too do not deplete the ozone layer. It will not release any harmful gas into the environment. This is environment friendly system. Low power consumption than either air conditioner around 70%. This systems will be the best air conditioning system than any other system. This system can be used in domestic as well as small areas like office, cabinets etc.

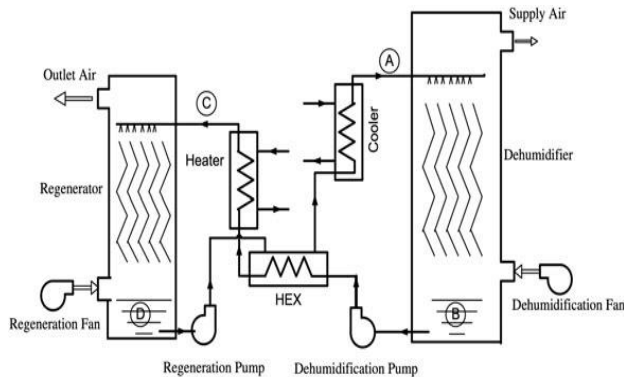

General Block Diagram

VI. CONCLUSION AND FUTURE SCOPE

A. Conclusion

Desiccant liquid is generally used for the dehumidification of air. It removes moisture as well as dry particles from it. We have used LiCl desiccant liquid in our system which will provide more efficient dehumidified air. As desiccant liquid do not harm environment as well as it too do not deplete the ozone layer. It will not release any harmful gas into the environment. This is environment friendly system. Low power consumption than either air conditioner around 70%. This systems will be the best air conditioning system than any other system. This system can be used in domestic as well as small areas like office, cabinets etc.

B. Future Scope

1. By changing some components and rearranging the system, overall system efficiency can be increased.

2. Cooling rate of the system is comparatively low than other air conditioning system. So cooling rate too can be increased for better comfort.
3. This designed system is only for domestic use. Therefore redesign the system for commercial, industrial use.
4. Availability of Liquid Desiccant in local areas is less. So providing this to customers a proper arrangement can be done.
5. Making the system more automized which can help the user to operate the system from remote location.

REFERENCES

- [1] Indramani Pandey and Dr. Kalpesh V. Modi, "Liquid Desiccant Air Conditioning System:A Review", Mechanical Engineering Department, Government Engineering College, Valsad, India. Volume 6, Issue 2 April 2018.
- [2] Deba Kumar Mahanta and Bipasha Sarma, "Regeneration of Solid and Liquid Desiccant:A Review", Electrical Engineering Department, Assam Engineering College Guwahati-781013, Assam, India, (ICPCSI-2017)
- [3] J.R.Mehta, "Regeneration of Liquid Desiccant using Solar Energy", Department of Mechanical Engineering, Faculty of Technology and Engineering, The Maharaja Sayajirao University of Baroda, Vadodara, INDIA, (ICONCE 2014)
- [4] Xinli Wanga, Xiaohong Yinb, Lei Wanga, Hongxia Zhao c, and Lei Jiaa, "A novel liquid desiccant air conditioning with batch-wise operation strategy", School of Control Science and Engineering, Shandong University, Jinan, 250061, China, published in 2018
- [5] Zhang Liang, Liu Jianhua, Zhang Haijiang, Ge qilin, Zhu Liwei, and Zhang huichen, "Application Research on Waste Heat Driven Liquid Desiccant Air-conditioning System", School of Energy and Power Engineering, University of Shanghai for Science and Technology, Shanghai, China, published in 2011
- [6] Minaal Sahlot and Saffa B. Riffat, "Desiccant cooling systems: a review", Department of Architecture and Built Environment, University of Nottingham, Nottingham NG7 2RD, UK, International Journal of Low-Carbon Technologies Advance Access published January 20, 2016
- [7] D. G. Waugaman, A. Kini, C. F. Kettleborough, "A Review of Desiccant Cooling Systems", Departments of Mechanical Engineering and Engineering Technology, Texas A&M University, College Station, TX 77843, 09/21/2016
- [8] Jin Wang, Cun_Nan Li, Jian_Hua Liu, Si_Chang Liu, Jun Chen, "A New Air-conditioning System of Liquid Desiccant and Evaporation Cooling", College of Urban Construction & Environmental Engineering, University of Shanghai for Science and Technology Shanghai, P.R. China, 2009 IEEE
- [9] Gaurav Kumar, "Liquid Desiccant Systems:A Review", Department of Mechanical Engineering, Cochin University of Science and Technology, Kochi-682022, INDIA, JETIR April 2019, Volume 6, Issue 4
- [10] H. Taherian, Hossein Ghadamian, Hesam Salarian, and Morteza khalaji assadi, "A Study of Liquid Desiccant System Performance", Conference Paper · January 2009